



AAVID
THERMALLOY

Xeon™ MP 2.8 GHz, Nocona™
3.2GHz 2U Heat Sink

**PASSIVE HEAT SINK FOR INTEL® XEON™ MP 2.8
GHZ, NOCONA™ 3.2GHZ PROCESSORS**

Aavid's solution for Xeon™ MP 2.8 GHz, Nocona™ 3.2GHz processor is designed specifically for thermal engineers who require cost effective solution for value 2U servers. The heat sink meets performance requirements for both thermal performance and weight.

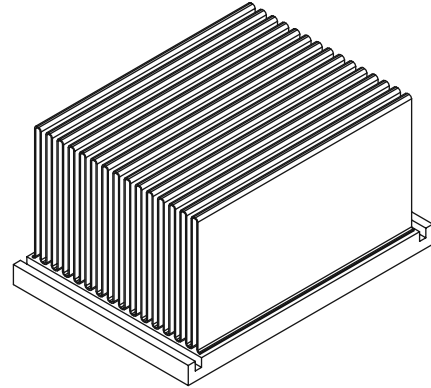

CRITICAL APPLICATION NEEDS:

- *Cooling capacity to support processor thermal requirements*
- *Ability to withstand shock and vibration without damage*
- *Easy to attach*

FEATURES AND BENEFITS:

- *Copper base and aluminum folded fin structure offers the necessary thermal performance with lower weight than full copper designs*
- *Use of aluminum fins lowers weight reducing strain on mounting hardware*
- *Mounts using two spring clips for easy no tools assembly*

ORDERING INFORMATION:

Part Number	Description
038288	Passive heat sink for Xeon™ MP and Nocona™ Processors
C564	Mounting Clip (2 required)

FOR MORE INFORMATION, VISIT OUR WEB SITE: WWW.AAVIDTHERMALLOY.COM
TEL: (603) 224-9988



AAVID THERMALLOY

Xeon™ MP 2.8 GHz, Nocona 3.2GHz 2U Heat Sink

MECHANICAL DRAWING:

Dimensions are shown as mm (in)

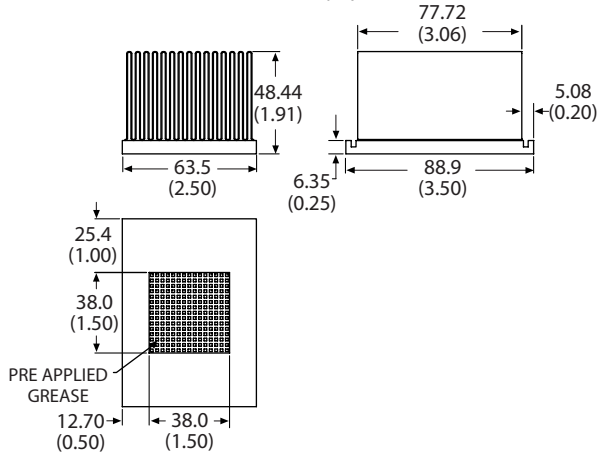

THERMAL PERFORMANCE:

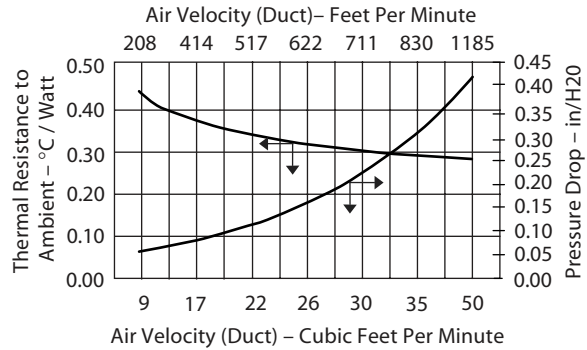

PHYSICAL SPECIFICATION:

Socket Type	603 pin and 604 pin	
Construction	Base plate	Copper
	Fins	Aluminum folded fin
Thermal Interface Material¹	Shin Etsu G749 grease	
Weight	450 grams	
Mechanical	Designed to meet Intel® shock and vibration requirements	

NOTES:

1. Contact factory for options on pre applied grease or phase change material

TEST PARAMETERS:

Test Platform: Aavid thermal test vehicle and wind tunnel along with Fluent Icepak simulation
 CPU Power: Modeled at 85W
 Testing in accordance with Intel test methodology with zero bypass.

North America

80 Commercial Street
 Concord, NH 03301
 TEL: (603) 224-9988
 FAX: (603) 223-1790
 EMAIL: info@aavid.com

Europe - Italy

Via Aprile,32
 40057 Cadriano (BO), Italy
 TEL: (39) 051 764011
 FAX: (39) 051 764090
 EMAIL: sales.it@aavid.com

Europe - England

Cheney Manor
 Swindon
 SN2 2QN
 England
 TEL: 44(0) 1793 401400
 FAX: 44(0)1793 615396
 EMAIL: sales.uk@aavid.com

Asia - Taiwan, R.O.C.

14F-4, NO. 79, Hsin Tai Wu RD.
 SEC. 1, Hsi Chih
 Taipei Hsien
 Taiwan, R.O.C.
 TEL: 011(886) 2-2698-9888
 FAX: 011(886) 2-2698-9808

Asia - Singapore

5 Woodlands Industrial Park E1
 Singapore 757728
 TEL: 65-6362-8388
 FAX: 65-6362-8588

PLEASE NOTE: Our customers are reminded that they bear the responsibility for testing Aavid Thermalloy's products for proposed use. Any information furnished by Aavid Thermalloy is believed to be accurate and reliable, but our customers must bear all responsibility for use and applications of Aavid Thermalloy products. AAVID THERMALLOY MAKES NO WARRANTIES EXPRESSED OR IMPLIED, AS TO THE FITNESS, MERCHANTABILITY, OR SUITABILITY OF ANY AAVID PRODUCTS FOR ANY SPECIFIC OR GENERAL USES. AAVID THERMALLOY SHALL NOT BE LIABLE FOR INCIDENTAL OR CONSEQUENTIAL DAMAGES OF ANY KIND. All Aavid Thermalloy products are sold pursuant to the Aavid Thermalloy Domestic Terms and Conditions of Sale in effect from time to time, a copy of which shall be furnished upon request (8911A). Copyright © Aavid Thermalloy, LLC. July 2004. All icons, drawings, illustrations, and trademarks are the property of Aavid Thermalloy, LLC. and may not be reproduced without express written permission. (7/2004)

FOR MORE INFORMATION, VISIT OUR WEB SITE: WWW.AAVIDTHERMALLOY.COM

TEL: (603) 224-9988