



AAVID
THERMALLOY

Heat Sink for Intel® Prescott LGA775 in 1U Servers

PASSIVE HEAT SINK FOR INTEL® PRESCOTT PROCESSORS

Aavid's solution for Prescott LGA775 processors is designed specifically for thermal engineers who require a high performance solution for single processor 1U servers. The heat sink offers excellent thermal performance while offering the advantage of low weight.

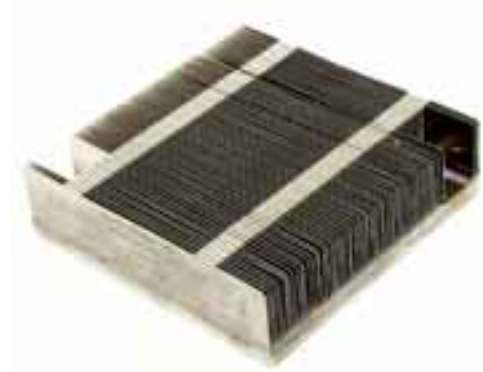

CRITICAL APPLICATION NEEDS:

- *Cooling capacity to support processor thermal requirements*
- *Good thermal performance in limited airflow*
- *Ability to withstand shock and vibration without damage*
- *Easy to attach*

FEATURES:

- *Design uses Aavid's patented HiContact™ heat pipe base to provide maximum thermal performance without the need for heavy, costly vapor chambers*
- *Optimized fins for recently improved 1U fans*
- *Light weight design reduces stress on the retention mechanism and processor*
- *Provisions for two point mounting*

ORDERING INFORMATION:

Part Number	Description
040592	Passive heat sink for Prescott LGS775 processors

FOR MORE INFORMATION, VISIT OUR WEB SITE: WWW.AAVIDTHERMALLOY.COM
TEL: (603) 224-9988



**AAVID
THERMALLOY**

Heat Sink for Intel® Prescott LGA775 in 1U Servers

PERFORMANCE

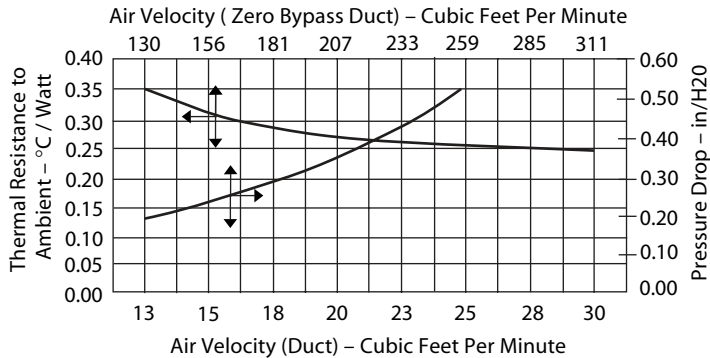

PHYSICAL SPECIFICATION:

Socket Type	775 LGA
Construction	Base plate: Aluminum with HiContact™ embedded heat pipe Fins: Stamped Aluminum fin
Thermal Interface Material¹	Not included
Weight	300 Grams
Mechanical	Designed to meet Intel® shock and vibration requirements

NOTES:

- Contact factory for options on pre applied grease or phase change material. Shin Etsu G751, X23-7783D grease, or Honeywell PCM45F phase change pad recommended.

TEST PARAMETERS:

Test Platform: Aavid thermal test vehicle and wind tunnel. Shin Etsu G751 grease applied
CPU Power: Tested at 115W+
Tested in accordance with Intel® test methodology with zero bypass.

MECHANICAL DRAWING:

Dimensions are shown as mm (in)

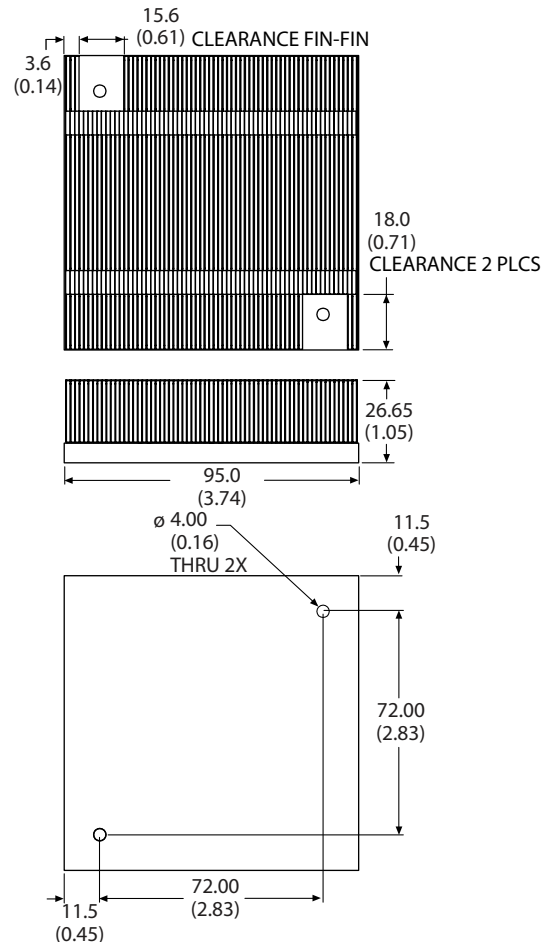

North America

80 Commercial Street
Concord, NH 03301
TEL: (603) 224-9988
FAX: (603) 223-1790
EMAIL: info@aavid.com

Europe - Italy

Via Aprile,32
40057 Cadriano (BO), Italy
TEL: (39) 051 764011
FAX: (39) 051 764090
EMAIL: sales.it@aavid.com

Europe - England

Cheney Manor
Swindon
SN2 2QN
England
TEL: 44(0) 1793 401400
FAX: 44(0)1793 615396
EMAIL: sales.uk@aavid.com

Asia - Taiwan,

14F-4, NO. 79, Hsin Tai Wu RD.
SEC. 1, Hsi Chih
Taipei Hsien
Taiwan
TEL: 011(886) 2-2698-9888
FAX: 011(886) 2-2698-9808

Asia - Singapore

5 Woodlands Industrial Park E1
Singapore 757728
TEL: 65-6362-8388
FAX: 65-6362-8588

PLEASE NOTE: Our customers are reminded that they bear the responsibility for testing Aavid Thermalloy's products for proposed use. Any information furnished by Aavid Thermalloy is believed to be accurate and reliable, but our customers must bear all responsibility for use and applications of Aavid Thermalloy products. AAVID THERMALLOY MAKES NO WARRANTIES EXPRESSED OR IMPLIED, AS TO THE FITNESS, MERCHANTABILITY, OR SUITABILITY OF ANY AAVID PRODUCTS FOR ANY SPECIFIC OR GENERAL USES. AAVID THERMALLOY SHALL NOT BE LIABLE FOR INCIDENTAL OR CONSEQUENTIAL DAMAGES OF ANY KIND. All Aavid Thermalloy products are sold pursuant to the Aavid Thermalloy Domestic Terms and Conditions of Sale in effect from time to time, a copy of which shall be furnished upon request (8911A). Copyright © Aavid Thermalloy, LLC. October 2004. All icons, drawings, illustrations, and trademarks are the property of Aavid Thermalloy, LLC. and may not be reproduced without express written permission. (10/2004)

FOR MORE INFORMATION, VISIT OUR WEB SITE: WWW.AAVIDTHERMALLOY.COM

TEL: (603) 224-9988